

Semi-automated production

Increase productivity and let your Zund operator multitask!

Create a semi-automated production workflow by combining the board-loading-feature, material transport system, and cutter extensions. A mechanical guide facilitates positioning of the next sheet/board while the cutter is still processing the previous one.

The advantages of this setup include:

- No cutter downtime during removal of cut pieces
- The next sheet can be loaded at any time during the cutting process (freeing up the operator)
- Actual stoppage between sheets is consistently short (approx. 20 sec.)

This board-loading-feature is ideal for situations where operators must attend to multiple cutters and/or concurrently perform other tasks.

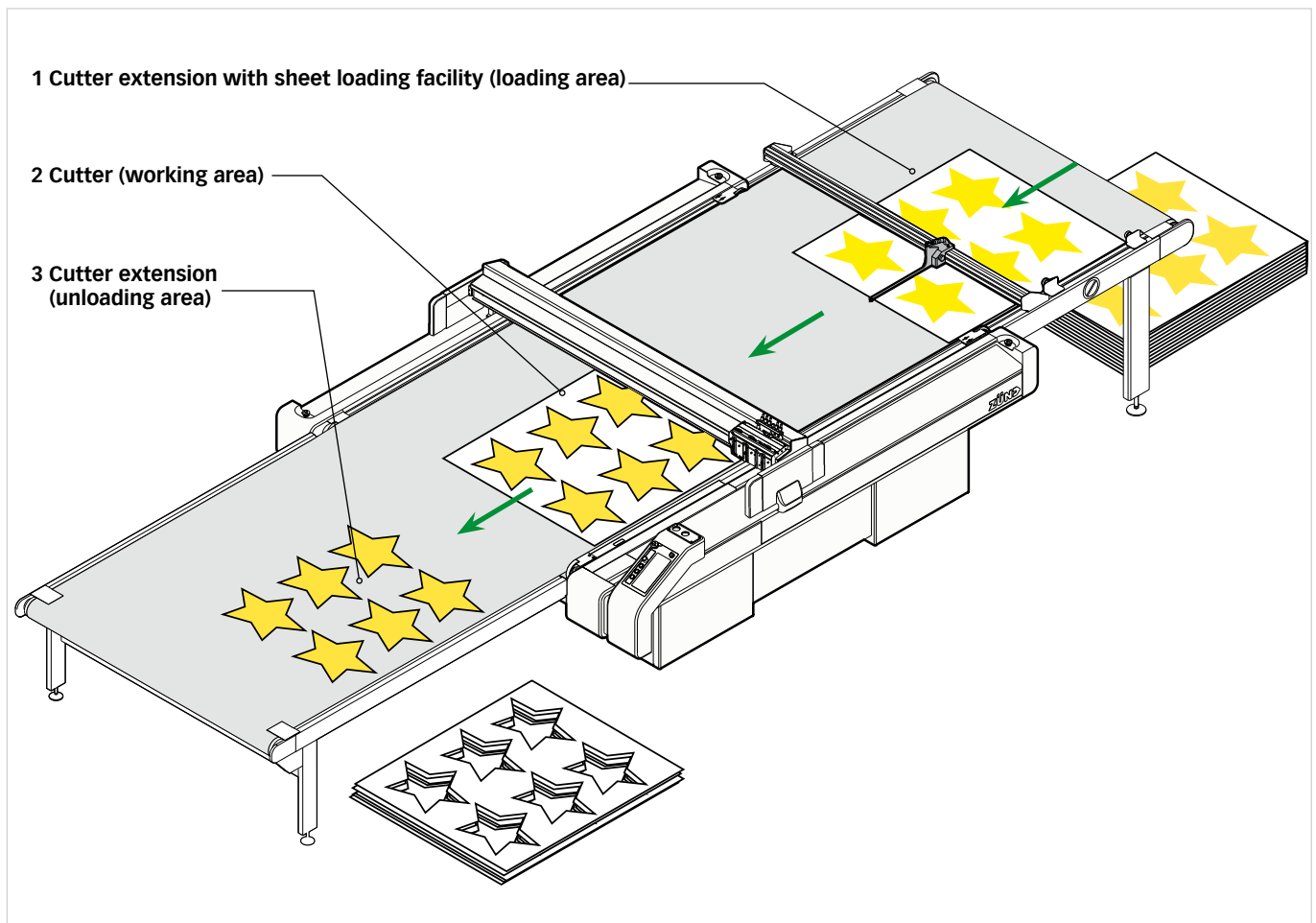

Increased productivity

Productivity often suffers because of the time it takes the operator to realize the cutter has finished cutting a sheet, then react, i.e. interrupt what he/she was doing, and finally replace the sheet for the machine to continue.

The semi automated production eliminates this reaction time and permits simultaneous processing and removal of cut pieces.

Overall productivity depends on:

1. Processing time - the time it takes to cut a sheet
2. Reaction time - the time it takes the operator to realize processing is completed and react
3. Unloading time - the time it takes to remove all cut pieces
4. Loading time - the time it takes to position a new, un-cut sheet

When working with the semi-automated workflow, the operator is given a window of time during the cutting process to prepare/position the next sheet and unload cut pieces.

Normal workflow



- Processing time varies depending on number of cut-outs, shapes, etc.
- Reaction time varies depending on what other tasks the operator is required to perform, and where
- Unloading time varies depending on number of cut-outs, type of material, etc.

Semi-automated workflow

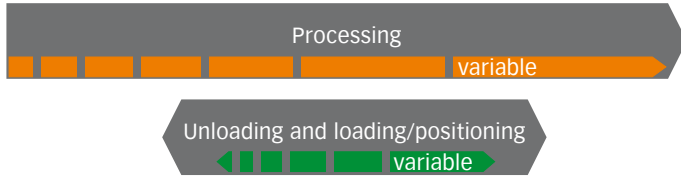

- Variable reaction time is eliminated
- Unloading can occur at any time during processing
- The result is a predictable, consistent workflow and overall increase in productivity

Cutter extension (unloading area)

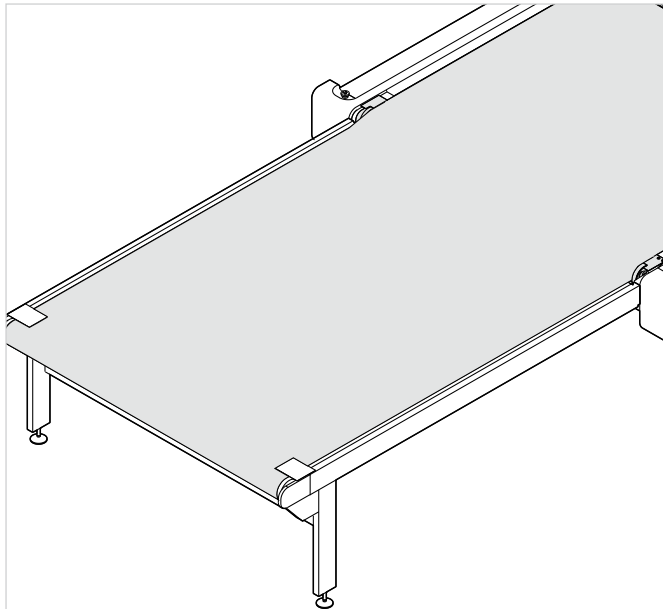

Cutter extension with sheet loading facility (loading area)

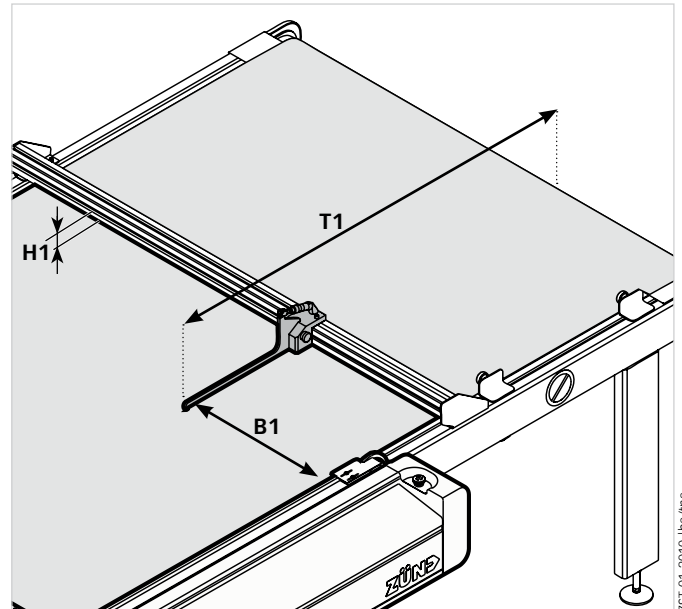

ZST-01-2010-lbe/ma

Options and requirements

- Cutter extension is recommended for unloading (not mandatory)
- available for all G3 with 60mm clearance
- Cutter extensions available in half- and full cutter length

Specifications

Length (of sheet/board supported) T1	Guide (adjustable width) B1	Material- thickness H1
cutter extension + 200mm	60-1000mm (with paws fix 60mm)	1-39mm

Headquarter
Zünd Systemtechnik AG
 Industriestrasse 8
 CH-9450 Altstätten
 T +41 71 757 81 00
 F +41 71 757 81 11
 info@zund.com
 www.zund.com

